

BUILDING A FOOD TRUCK

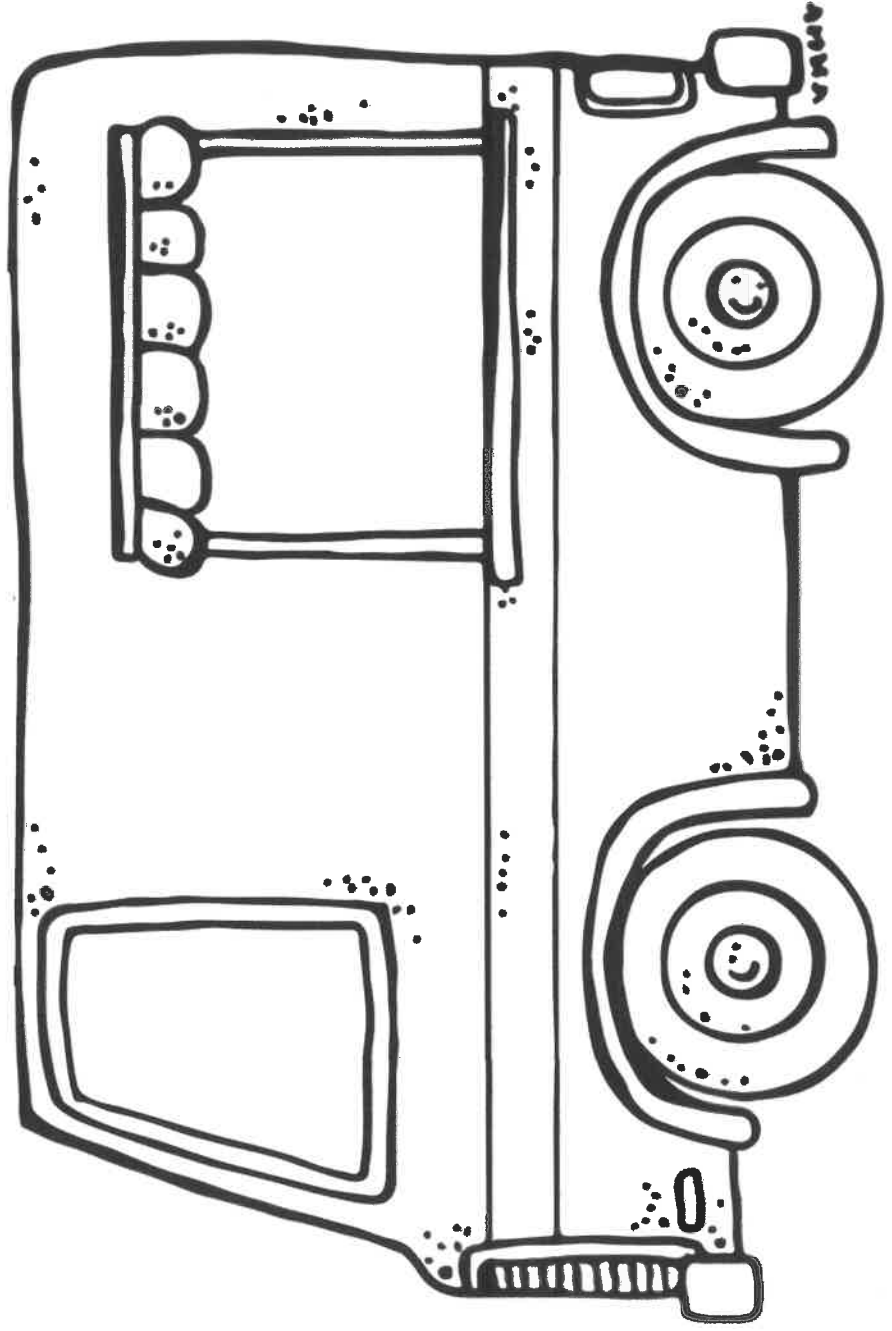

name

FOOD TRUCK PARTS

Things To Know

REQUIREMENTS LIST

Your food truck will have a list of items that must be included.

This will be a list of items for the floor plan and the walls. You will decide where to put everything!

This includes a COUNTER and open wall to serve customers.

AREA & PERIMETER

As you create the layout of the truck, you will need to find the area and perimeter of items from the requirement list.

Units will be the measurement used for perimeter and area.

Example:

-Perimeter is 24 units

-Area is 26 square units (or units squared).

GEOMETRY DESIGN

Use your geometry skills to find the best solution to fitting all items into the truck.

All cars and trucks are filled with geometry in real life. Use those ideas to help you make the best choices.

Math is everywhere!

BE PREPARED!

Your food truck must make sense and fit together. Make sure you leave space for the driver to drive it!

FOOD TRUCK PARTS

There are four major parts of the truck that you will build and design.

THE BASE

This is where you create the floor of the truck.

-The truck base is bolded, but the paper is full size to help with keeping the truck together.

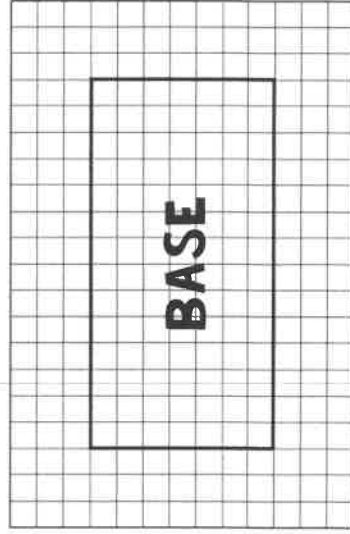

THE WALL, PIECE 1

Each WALL section contains two walls.

They are folded to create the front, back and sides of the truck.

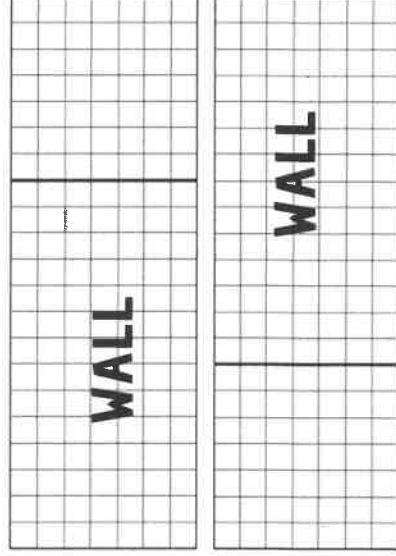

THE WALL, PIECE 2

They can be cut out to create a rectangle

that fits exactly around the base of the truck.

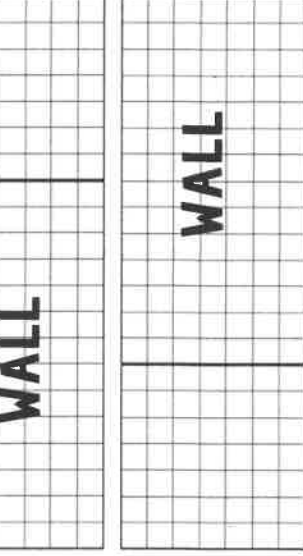

THE ROOF

The final part of the truck.

The size is just a little large so it can sit on top of the truck without falling apart.

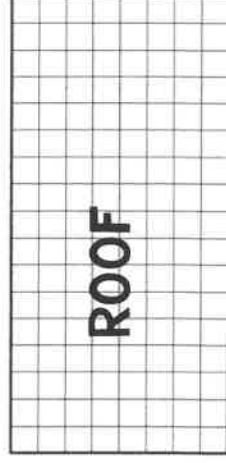

Each of the MAJOR PARTS will be on separate pieces of paper. They can be cut out and placed together to form a FOOD TRUCK in the shape of a rectangular prism.

FOOD TRUCK PARTS

More important things to know.

After you have created the layout, you will have to find the area and perimeter of items in the truck. Not all items will be exactly perfect, so estimate as close as you can.

You will design the base using a bird's eye view. Imagine looking straight down as you add in the furniture and lay it all out.

This is an example of a BASE floor plan.

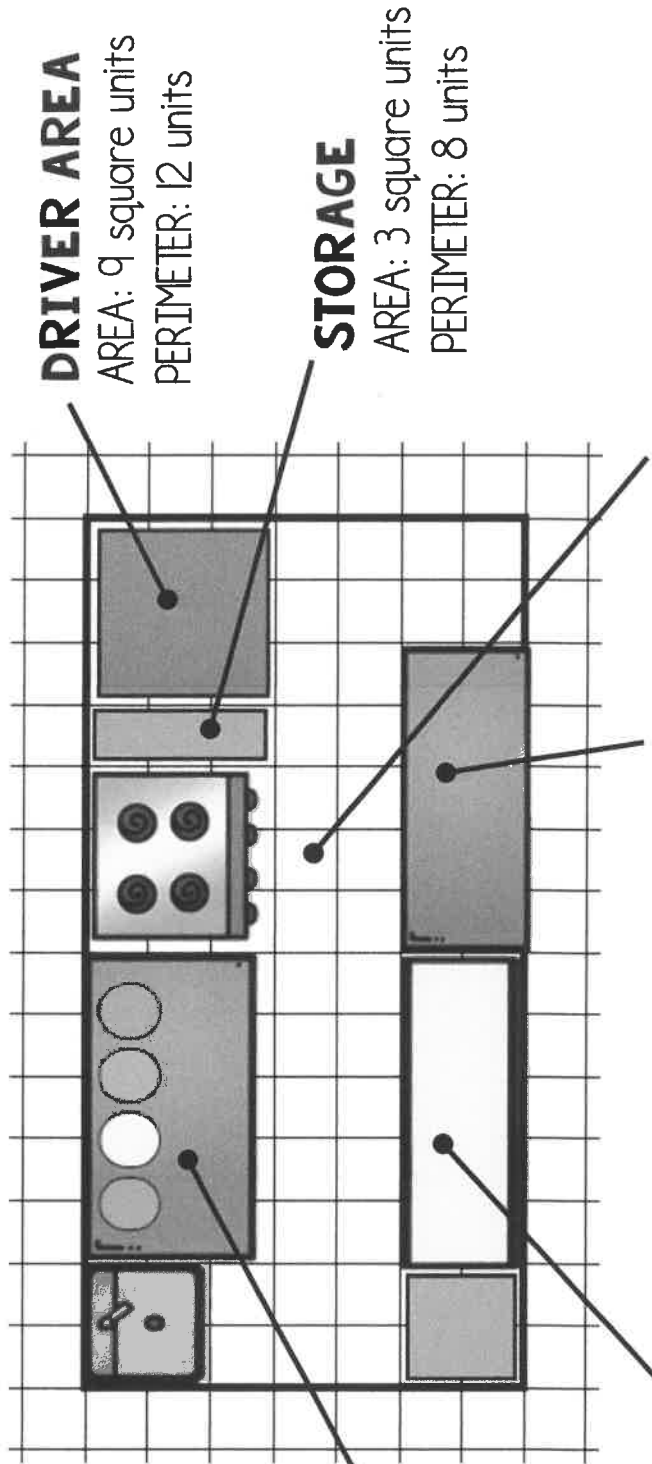

DRIVER AREA
AREA: 9 square units
PERIMETER: 12 units

STORAGE
AREA: 3 square units
PERIMETER: 8 units

COUNTER
AREA: 15 square units
PERIMETER: 16 units

WALKWAY
What is the AREA?
What is the PERIMETER?

WORK TABLE
AREA: 10 square units
PERIMETER: 4 units

CHECK OUT COUNTER
What is the AREA?
What is the PERIMETER?

ROUGH DRAFT: INSTRUCTIONS

This rough draft will be used as a blueprint and will include all items from the Requirement List. The Requirement List will be included on the page. Check off each item once you have included it.

This is the BASE and main floor.

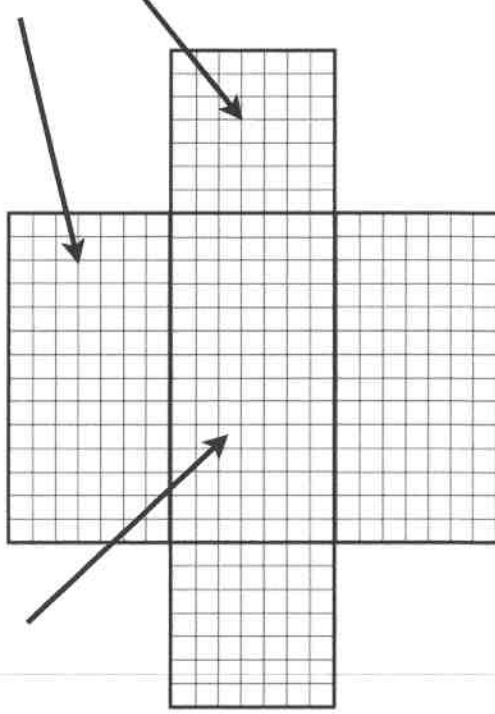

The inside of the truck will look like the four walls have been laid down.

Refer back to the directions and look at the examples to help you out.

A finished wall or base could look like this. Design carefully!

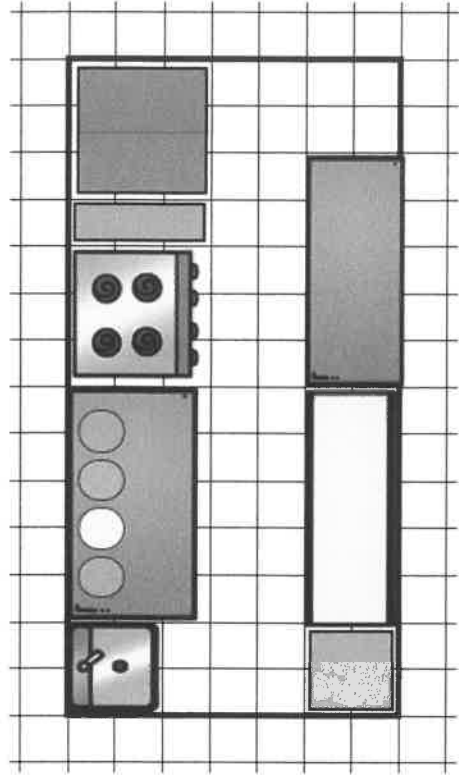

As seen on the previous page.

As you design the layout, you may have to turn your paper so the drawings match up on each side of the truck.

ROUGH DRAFT: BLUEPRINTS

Create your rough draft of the food truck. Check off each item after you add it to your truck.

driver seat	
work counter	
sink	
oven	

trash can	
order counter	
stove top	
window over order counter	

WALL

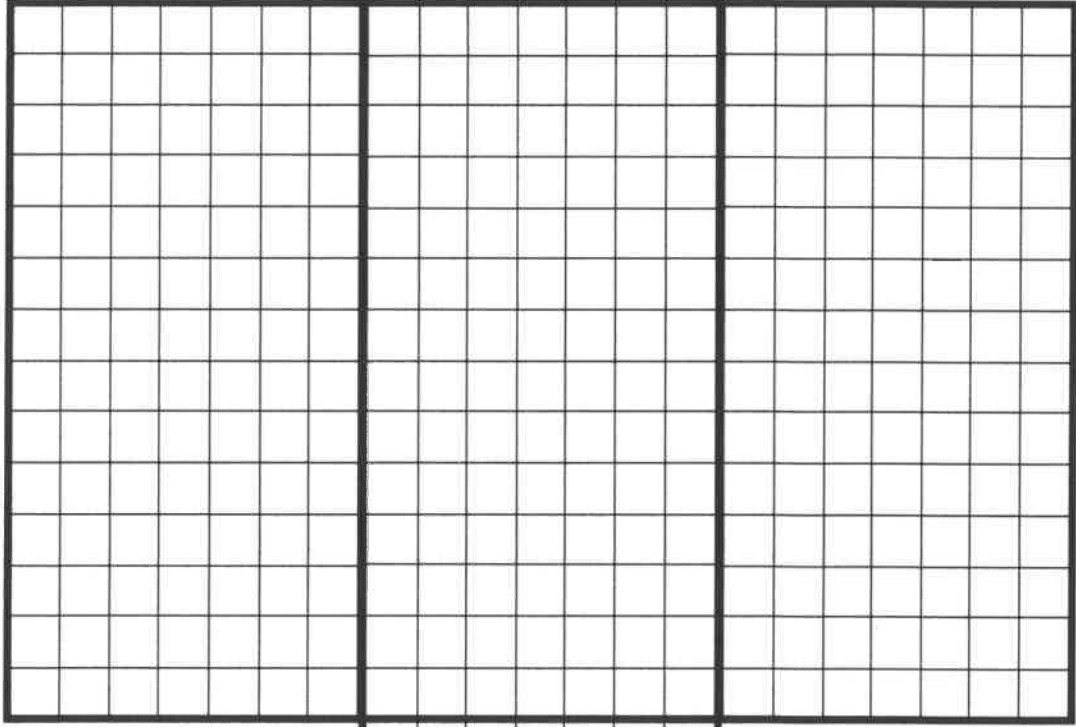

WALL

Walkway down the middle of the truck.	
EXIT out of the back of the truck.	

cash register	
supply cabinet	
freezer	

WALL

FINAL VERSION: REQUIREMENT LISTS

Listed below are all the furnishing elements that must be included inside your truck.

Check off each item once it has been added in your truck.

ITEM	COMPLETED
driver seat	
work counter	
sink	
oven	
trash can	
order counter	
stove top	

ITEM	COMPLETED
Walkway down the middle of the truck.	
EXIT out of the back of the truck.	
cash register	
supply cabinet	
freezer	
window over order counter	

FINAL VERSION: BASE FLOOR PLAN

Convert your rough draft to the final version of the truck.

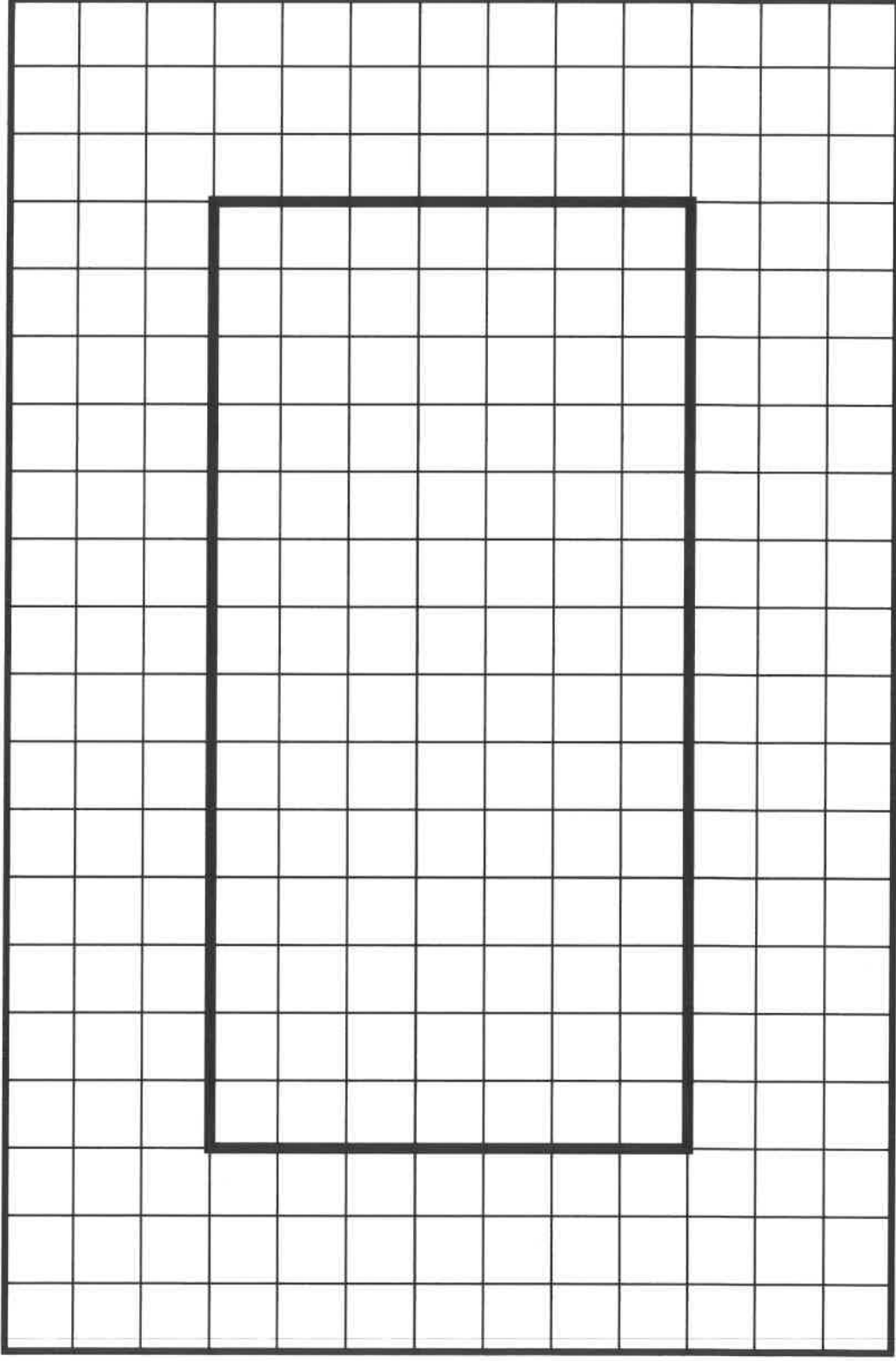

You may also design the surrounding area, which could look like roads, pavement, or something based on where the truck is parked.

FINAL VERSION: WALLS

The inside walls of the food truck are where you will continue designing from your floor plan.
MAKE SURE you keep enough space over the ORDER COUNTER so it can be cut open later.

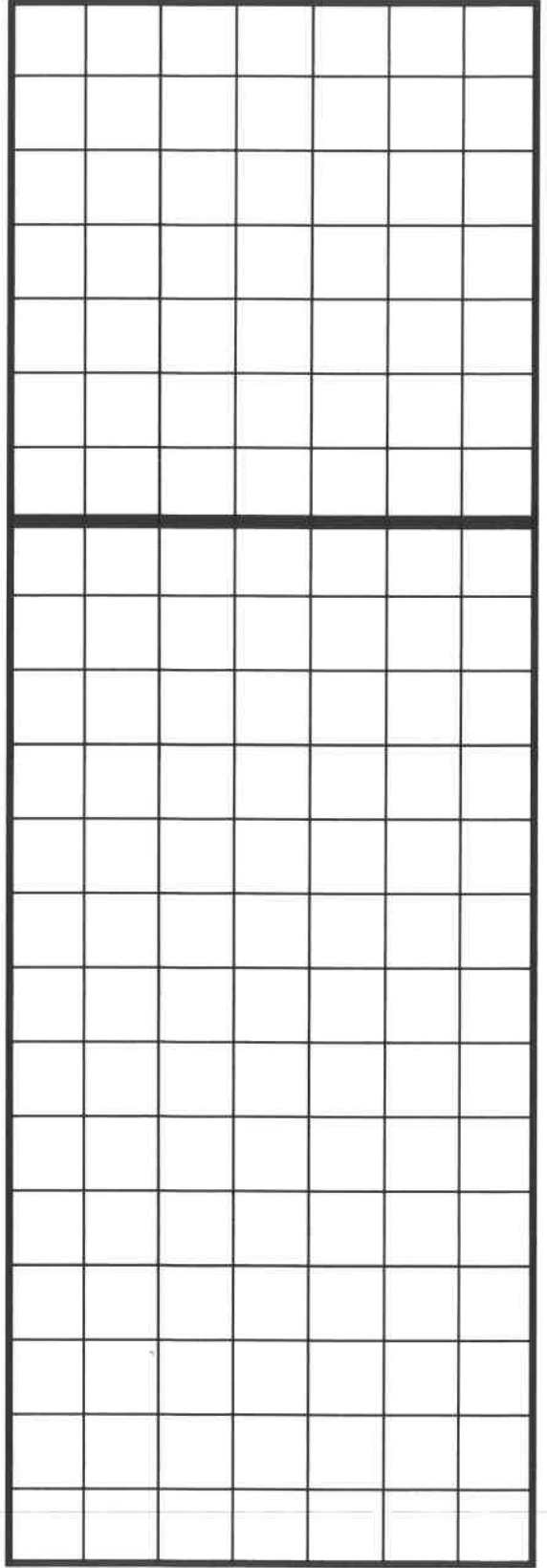
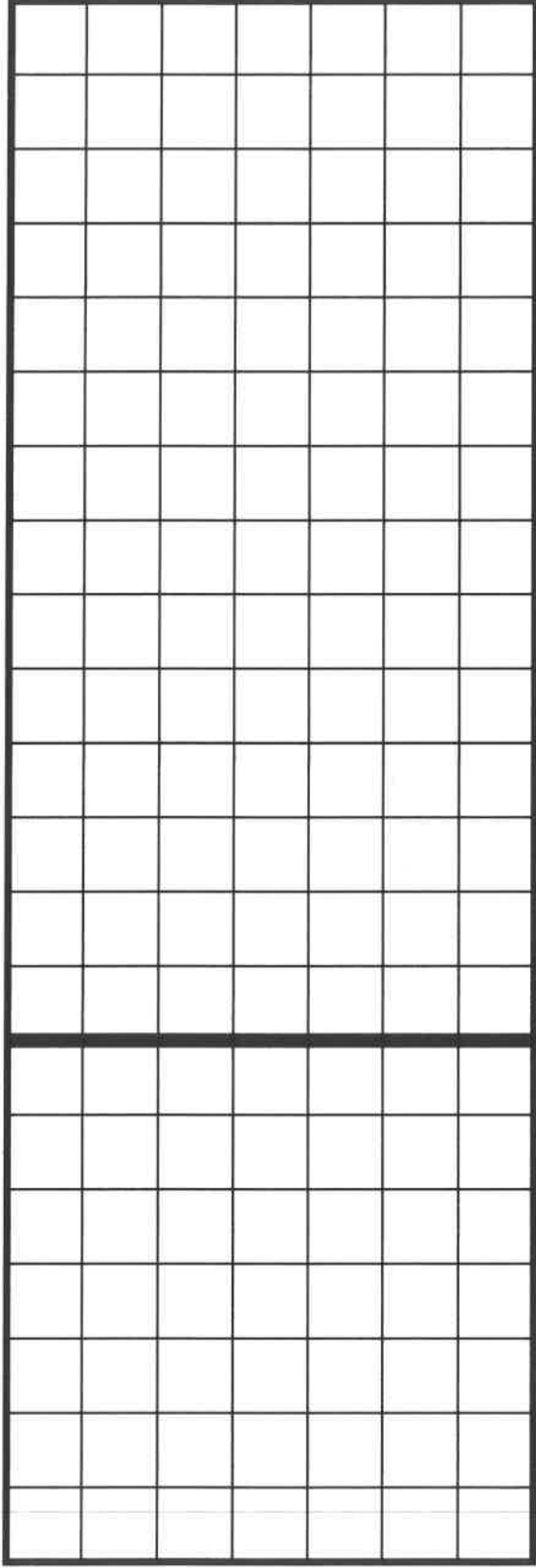

FINAL VERSION: ROOF & CEILING

Include any remaining items that could go on the roof and ceiling.

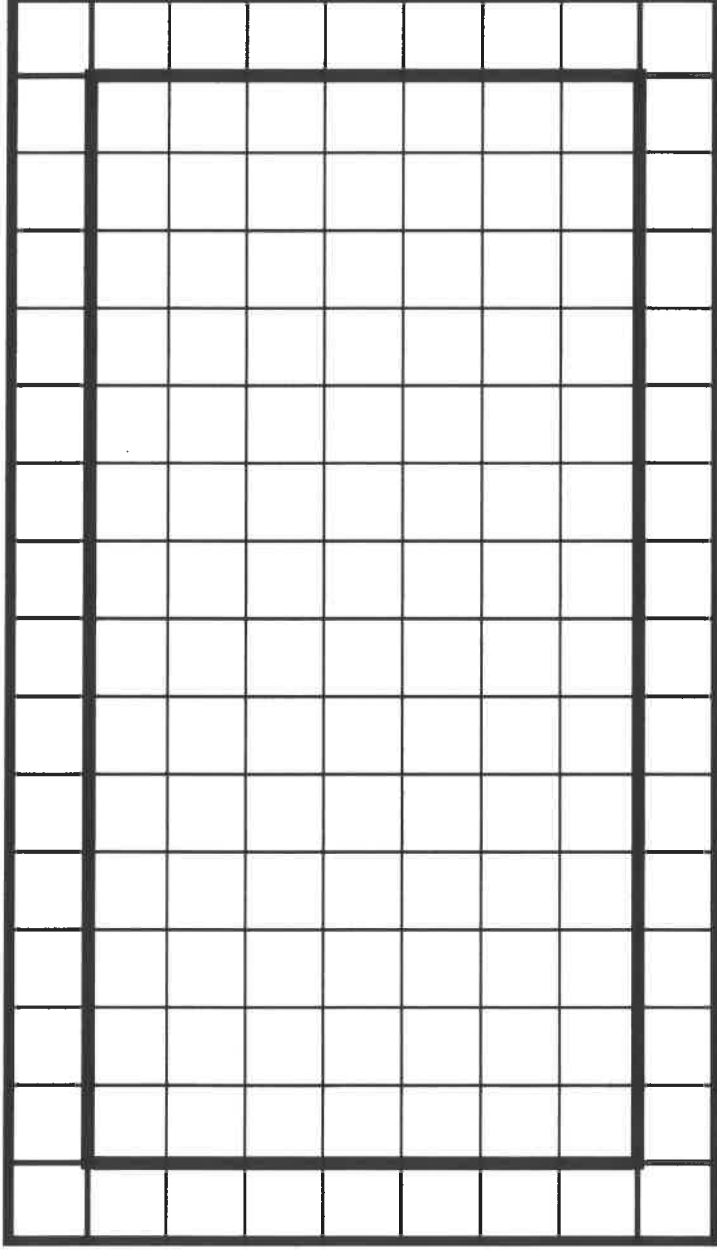

There is a single row of units that will hang over the side.

This is because the roof will sit on top of the walls.

You may cut down the roof sides once you see how it fits on top of the truck.

FOOD TRUCK SIZE

Find the AREA, PERIMETER, and SHAPE of each item in the truck.

Fill in the information below.

ITEM	PERIMETER	AREA	SHAPE
driver seat			
work counter			
sink			
oven			
trash can			
order counter			
stove top			
Walkway down the middle of the truck.			
EXIT out of the back of the truck.			
cash register			
supply cabinet			
freezer			
window over order counter			

FOOD TRUCK SIZE

Find the AREA, PERIMETER, and SHAPE of each item in the truck.
Fill in the information below.

ITEM	PERIMETER	AREA	SHAPE
------	-----------	------	-------

driver seat			
work counter			
sink			
oven			
trash can			
order counter			
stove top			

FOOD TRUCK SIZE

Find the AREA, PERIMETER, and SHAPE of each item in the truck.

Fill in the information below.

ITEM	PERIMETER	AREA	SHAPE
Walkway down the middle of the truck.			
EXIT out of the back of the truck.			
cash register			
supply cabinet			
freezer			
window over order counter			

BUILDING 3D APPLIANCES & FURNITURE

It's time to build your appliances by creating three dimensional shapes. There are two blank graphing sheets provided.

FIRST: Make sure your furniture size matches what you created in your truck.

SECOND: 3D (three dimensional) means you'll have to design on all the sides (or most of them). Minecraft and LEGOS are good examples.

THIRD: Don't cut out the net until you are sure you have enough. Map out what you need.

FOURTH: Tape your shapes together. You can try glue, but it might not work as well.

FIFTH: DON'T get discouraged! This is a very difficult element of design. It will take you a while to master it...but you can do it!

WALLS: If you created walls--add those!

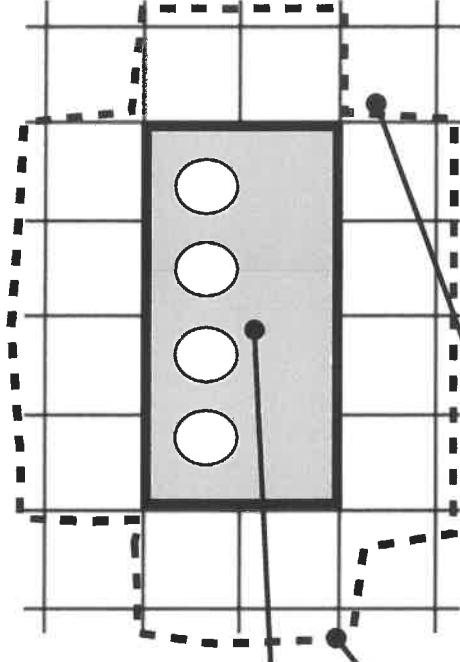

For this counter, I would cut out on my dotted line and tape the 4 sides together.

REMEMBER:

YOU MAY HAVE A BETTER WAY TO MAKE 3D APPLIANCES AND FURNITURE. DO WHAT WORKS BEST FOR YOU!

THREE-DIMENSIONAL PIECES

Use this graph paper to create your own three-dimensional appliances for the truck.

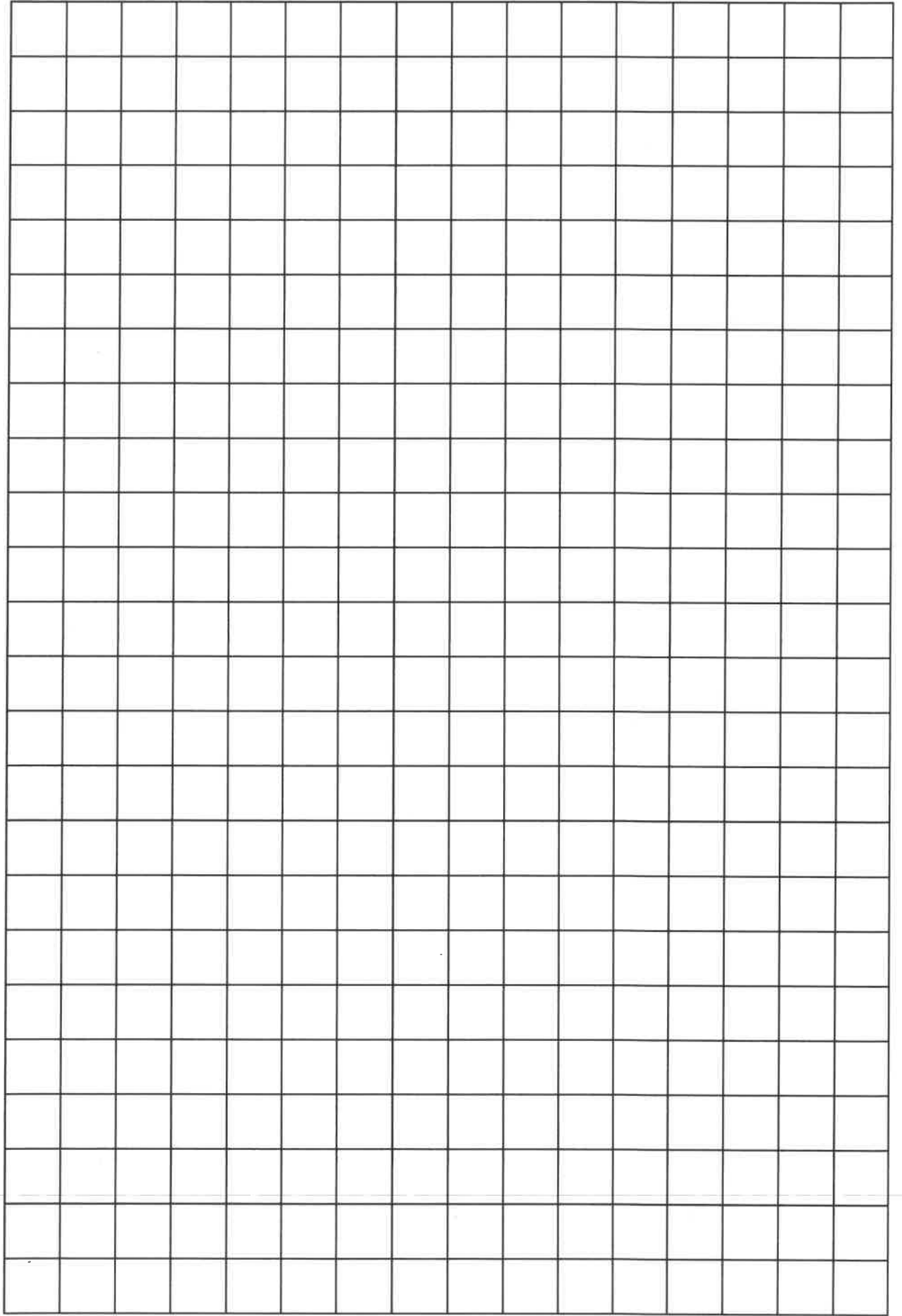

THREE-DIMENSIONAL PIECES

Use this graph paper to create your own three-dimensional appliances for the truck.

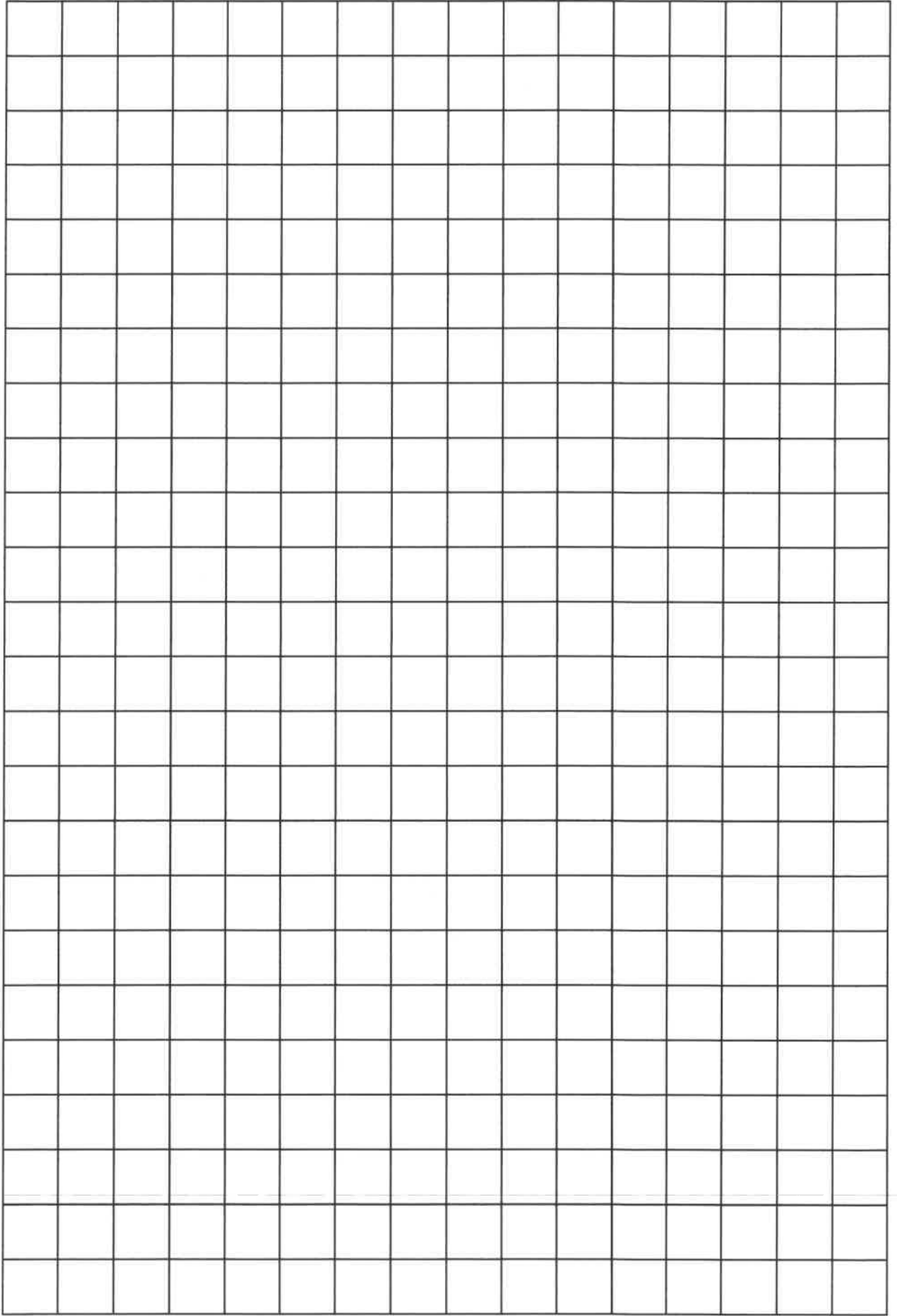

FOOD TRUCK EXTERIOR

Great work! You've designed the inside of the food truck and it is amazing!
Now you need to make the outside look just as good.

BE CAREFUL with coloring!

- ONLY USE crayons or colored pencils.
- Markers could bleed through and ruin the inside.
- Look at some pictures of food trucks to see what the outsides look like.

Window Counter

- Remember where you will put the window counter as you design.
- You can cut-out the entire side or create a fold up section.

TIRES and SIDES

- Decide on the tires and where to put them.
- On the side of the truck you can add the business name, logo, and other marketing ideas.

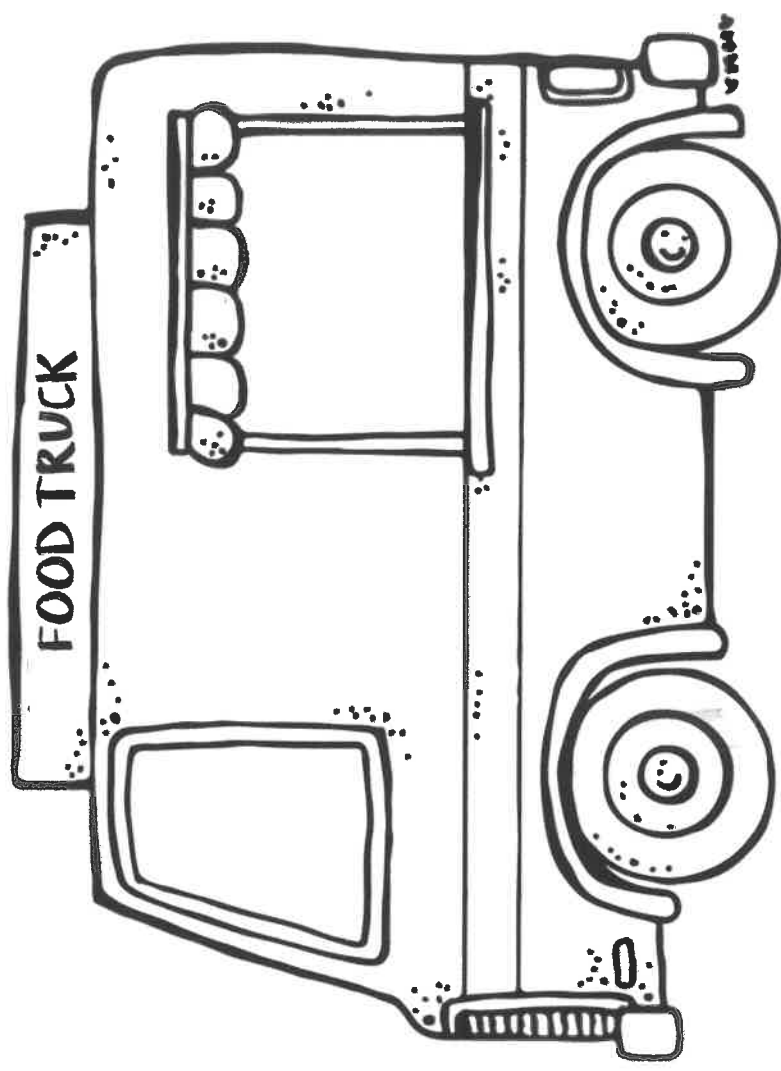

WINDOWS and DOORS

- If you are up to the challenge, try cutting out where you have windows.
- Be patient and work slow.

FOOD TRUCK EXTRAS

EXCELLENT! You've finished every single thing!
Now, go back and add the little details.

WHAT ARE LITTLE DETAILS?

The little details will make your truck and business come alive. Add in all the extras that you'd find at real food stops. Here are some ideas:

- supply boxes
- cooking appliances
- garbage can (for the sidewalk)
- tables and chairs
- generator or butane tank
- signs
- hanging lights
- cones
- people

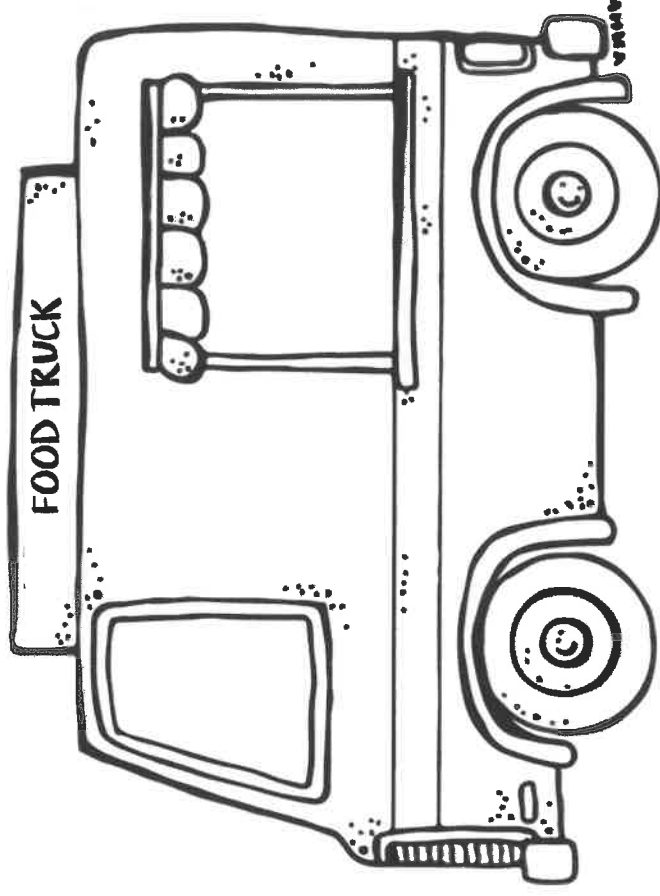

Your options are unlimited, so take your time as you create them. You will be amazed at how much of a difference the littlest detail makes.

STUDENT REFLECTION SHEET

Included is a student reflection sheet that students may use at the end of the project.

TEACHER RUBRICS

Included are two versions of rubrics.

Choose the version that works best for your class.

The first is a **single-point rubric**. If students are proficient in each category (running down the middle) you can circle the criteria. If they exceed or need more work with each criteria, there is space for you to give a specific example. This version requires more writing (from the teacher), but works well if your school is not using traditional grading systems.

The second rubric is more **traditional using a 5-point scale**. Teachers determine the scoring based on how they performed with the project, which is totaled at 25 points. The two final criteria options are based on problem-solving and collaboration. Those do not have a score. Students either exceed, meet, or need more work. Extra space is provided to write in, too.

NAME

PROJECT REFLECTION

I CAN...	YES	NEEDS MORE WORK
I completed all sections of this project that were required.		
I can apply decimals to my work and find totals using those decimals.		
I can find the area and perimeter of an object I create.		
I can connect area, perimeter, and geometry to real-world situations.		
I can use problem-solving techniques to complete this activity.		
I can use collaboration techniques to complete this activity.		

THE MOST CHALLENGING PART OF THIS PROJECT WAS...

MY FAVORITE PART OF THIS PROJECT WAS...

ONE THING THAT REALLY SURPRISED ME WAS...

SOMETHING I LEARNED FROM A CLASSMATE WAS...

SCORING RUBRIC

STUDENT NAME: _____

AREA NEEDS MORE WORK	PROFICIENT	EVIDENCE OF EXCEEDING STANDARD
	Student completed the required sections of the project.	
	Demonstrates an understanding of decimals and applying them correctly when finding totals.	
	Demonstrates an understanding of finding area and applying it correctly.	
	Demonstrated an understanding of finding perimeter and applying it correctly.	
	Connects the concepts of decimals, perimeter, and area to real-world settings (running a business).	
	Applied multiple problem-solving skills to complete the activity.	
	Applied collaboration skills to complete the activity	

SCORING RUBRIC

STUDENT NAME: _____

CRITERIA	MET STANDARD					AREA NEEDS MORE WORK
Student completed the required sections of the project.	5	4	3	2	1	1
Demonstrates an understanding of decimals and applying them correctly when finding totals.	5	4	3	2	1	1
Demonstrates an understanding of finding area and applying it correctly.	5	4	3	2	1	1
Demonstrated an understanding of finding perimeter and applying it correctly.	5	4	3	2	1	1
Connects the concepts of decimals, perimeter, and area to real-world settings (running a business).	5	4	3	2	1	1
Applied multiple problem-solving skills to complete the activity.	EVIDENCE OF EXCEEDING		MET			
Applied collaboration skills to complete the activity	EVIDENCE OF EXCEEDING		MET			

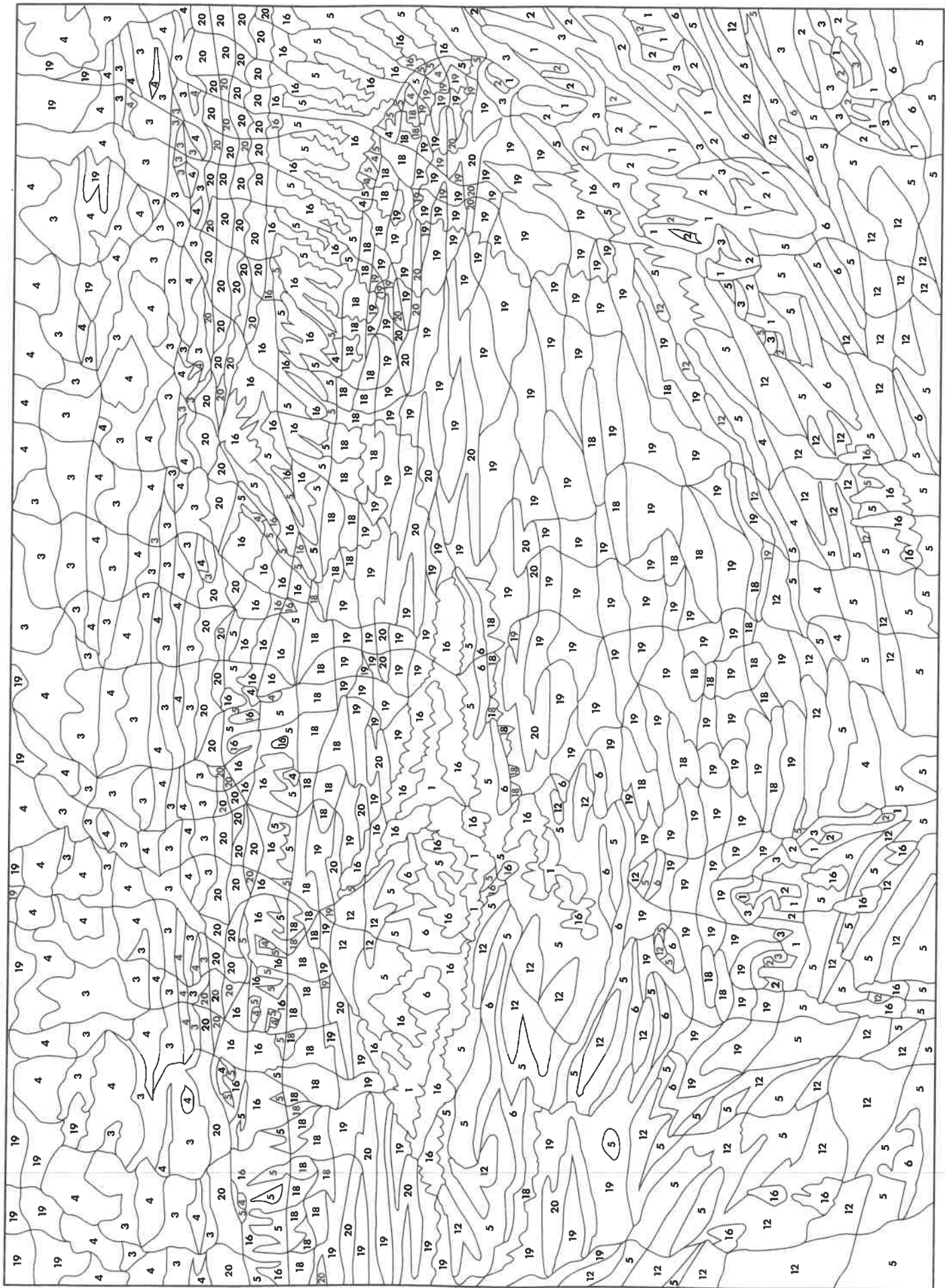

**COLORS
TO USE**

- 1
- 2
- 3
- 4
- 5
- 6
- 12
- 16
- 18
- 19
- 20

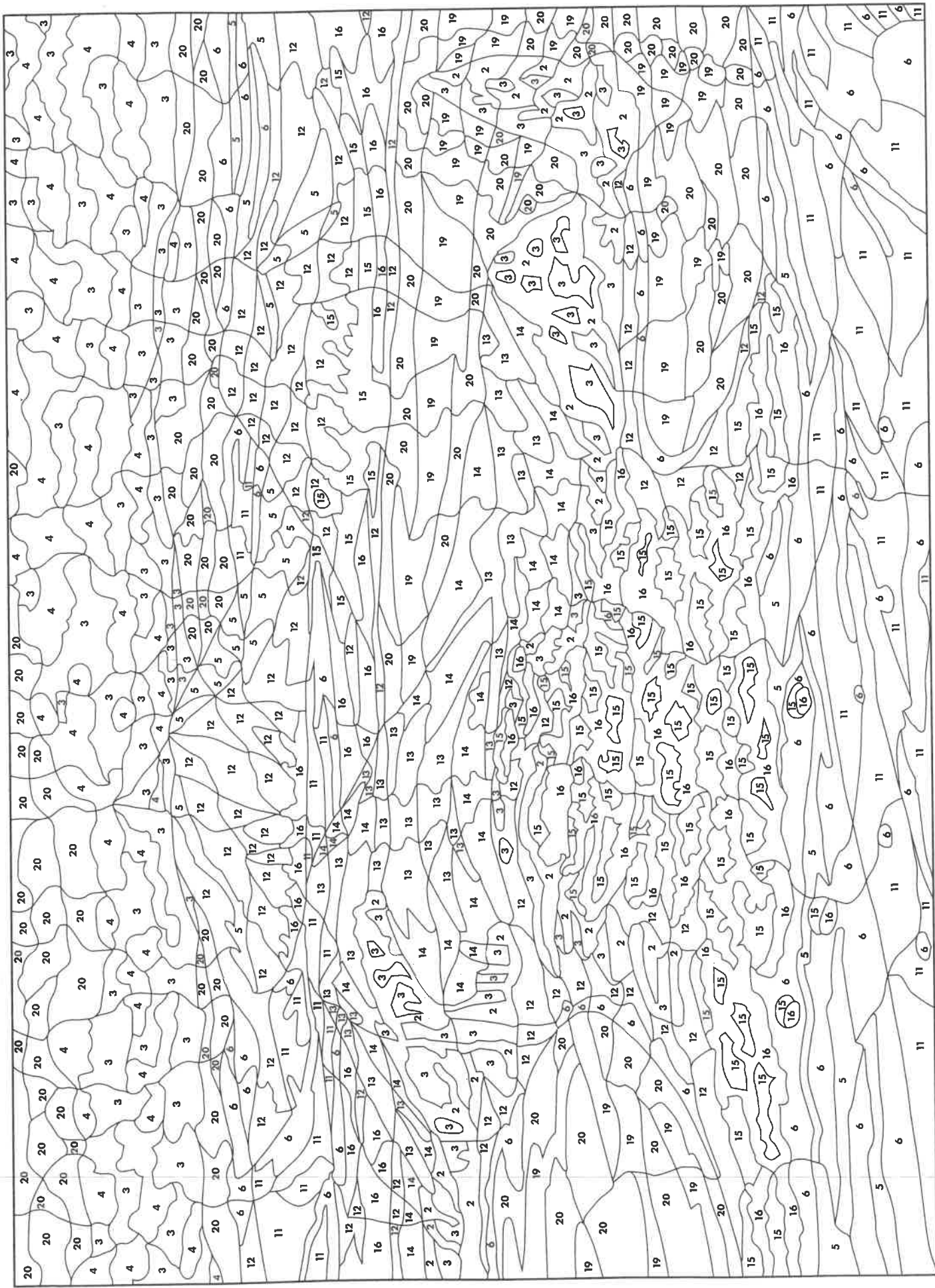

**COLORS
TO USE**

- 2**
- 3**
- 4**
- 5**
- 6**
- 11**
- 12**
- 13**
- 14**
- 15**
- 16**
- 19**
- 20**

TABLE OF CONTENTS

PAGE	CONTENT
6	About this Resource & Instructions
9	Cover Page & Intro
11	SECTION ONE: START -UP
12	Business Name, Logo & Design (two versions to choose from)
14	Slogans, Hours, and Problems You Could Face
15	SECTION TWO: MAKING THE MENU
17	Brainstorm
18	Picking the Menu and Pricing
20	Building Food Meals (decimals)
21	Combo Platter (adding with decimals)
22	Taking Student Orders (students find totals and costs)

PAGE	CONTENT
27	Taking Orders, Secret Menu
30	Design the Menu
36	SECTION THREE: BUILDING THE TRUCK
41	Rough Draft
42	Final Version
46	Food Truck Size, Area and Perimeter
49	Building Appliances and Furniture
52	Exterior and Extras
54	Teacher Rubrics and Student Reflections
58	Visuals for creating the food truck.
72	EXTRA pages that DO NOT include required decimals.
72-75	Digital downloads link and instructions for Google Slides